

TECHNICAL DATA SHEET FOR P12M PROOFER/HOLDING CABINET

Full Size Manual / Electric

STANDARD FEATURES

- Dual function Proofer and Holding Cabinet
- Designed for individual use or system installed with Turbofan 32D Convection Ovens
- 12 full size sheet pan capacity
- 24 half size sheet pan capacity
- 2⁷/₈" / 74mm tray spacing
- Compact 28⁷/₈" / 735mm width
- 110-120V plug-in
- 20A NEMA 5-20P cordset fitted
- Full double skin construction
- Auto water fill system with optional integrated water filter kit
- Continuous door seal
- Side hinged door (standard LH hinge). Optional RH hinge (field convertible)
- Off / Proof / Hold mode selection
- Low velocity circulation fan system
- Mechanical thermostat
- Humidity level control
- Dual halogen cabinet interior lamps
- Cabinet temperature display thermometer
- 4 dia. 3" / 76mm castors with 2 front castors dual wheel and swivel lock, 2 rigid rear castors
- 100% recyclable packaging

ACCESSORIES

- Optional 3M Cuno water filter kit complete with cartridge and connection fittings
- Installs in pre-fitted rear housing of cabinet for flush rear installation



P12M

Unit shall be a Blue Seal electrically heated Turbofan Proofer and Holding Cabinet ETL Listed and NSF-4 listed. The proofer and holding cabinet shall have double skin construction with stainless steel interior and exterior sides, front and top. Door shall be side hinged and field reversible. Unit shall have capacity for up to 24 half size sheet pans or 12 full size sheet pans. A single speed fan shall gently and evenly circulate air around the cabinet. Cabinet shall be controlled by a mechanical thermostat and humidity via a control of the water tank. A thermometer shall indicate the cabinet temperature. Proofer and holding cabinet shall be mounted on castors, with two rigid castors at rear and two swivel castors dual swivel and wheel lock and front. Proofer and Holding cabinet shall operate independently or in combination with Blue Seal Turbofan model E32D5 or G32D5 Convection Ovens. Proofer and Holding Cabinets shall be fitted with NEMA 5-20P cordsets. Unit shall be supplied in 100% recyclable shipping packaging.

P12M Full Size Manual / Electric Proofer/Holding Cabinet

CONSTRUCTION

304 stainless steel interior cabinet
 Stainless steel front, sides and top exterior
 Stainless steel interior side racks
 Stainless steel frame side hinged door
 0.2" / 5mm thick door glass
 Stainless steel control panel
 Aluminized coated steel base and rear panels

CONTROLS

Off / Proof / Holding mode selector switch.
 Mechanical thermostat 65-185°F / 20-85°C
 Air heating ON control panel indicator
 Humidity level control
 Humidity tank ON control panel indicator
 Cabinet temperature thermometer
 Auto-fill water system standard

CLEANING

Stainless steel top and side exterior panels
 Stainless steel interior chamber
 Easy access to all interior surfaces
 Fully removable stainless steel rack support
 Removable humidity water tank (no tools)

SPECIFICATIONS

Electrical Requirements
 110-120V, 50/60Hz, 1-phase, 1.95kW, 15.6A
 NEMA 5-20P cordset fitted



Water Requirements (optional)

Cold water connection ¾" GHT male
 80psi maximum inlet pressure / 20psi minimum inlet pressure

External Dimensions

Width 28 7/8" / 735mm
 Height 44 1/2" / 1129mm including dia. 3" / 76mm castors
 Depth 31 7/8" / 810mm

Proofer Internal Dimensions

Width 18 1/4" / 465mm
 Height 37 1/4" / 945mm
 Depth 27 1/2" / 700mm
 Volume 11ft³ / 0.31m³

Nett Weight (P12M)

194 lbs / 88kg

Packing Data (P12M)

236lbs / 107kg
 32.1 ft³ / 0.91m³
 Width 30" / 760mm
 Height 51" / 1295mm
 Depth 36 3/8" / 925mm

INSTALLATION CLEARANCES

Rear 0" / 0mm
 LH Side 0" / 0mm
 RH Side 1" / 25mm

CLEARANCE FROM SOURCES OF HEAT

A minimum distance of 12" / 300mm from the appliance sides is required

BLUE SEAL

www.moffat.com
 www.turbofanoven.com
 www.servecanada.com

CANADA

Serve Canada
 22 Ashwarren Road
 Downview
 Ontario M3J 1Z5
 Ph Toll Free 800-263-1455
 Ph 416-631-0601
 Fax 416-631-7687
 Email info@servecanada.com

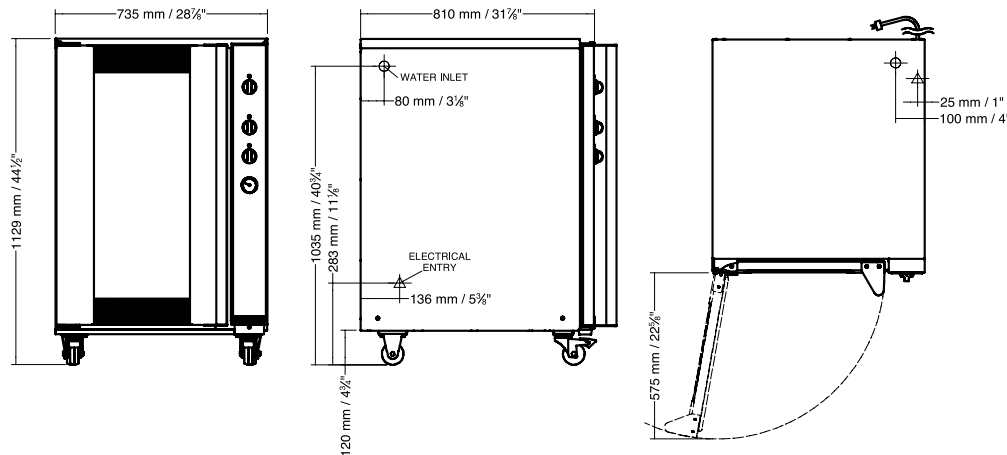

Manufactured by:
 Moffat Limited
 16 Osborne Street PO Box 10-001
 Christchurch 8081 New Zealand



Designed and manufactured by



ISO9001
 All Turbofan products are designed and manufactured by Moffat using the internationally recognised ISO9001 quality management system, covering design, manufacture and final inspection, ensuring consistent high quality at all times.

In line with policy to continually develop and improve its products, Moffat Limited reserves the right to change specifications and design without notice.



© Copyright Moffat Ltd
 Moffat 1271 / 3.12

